

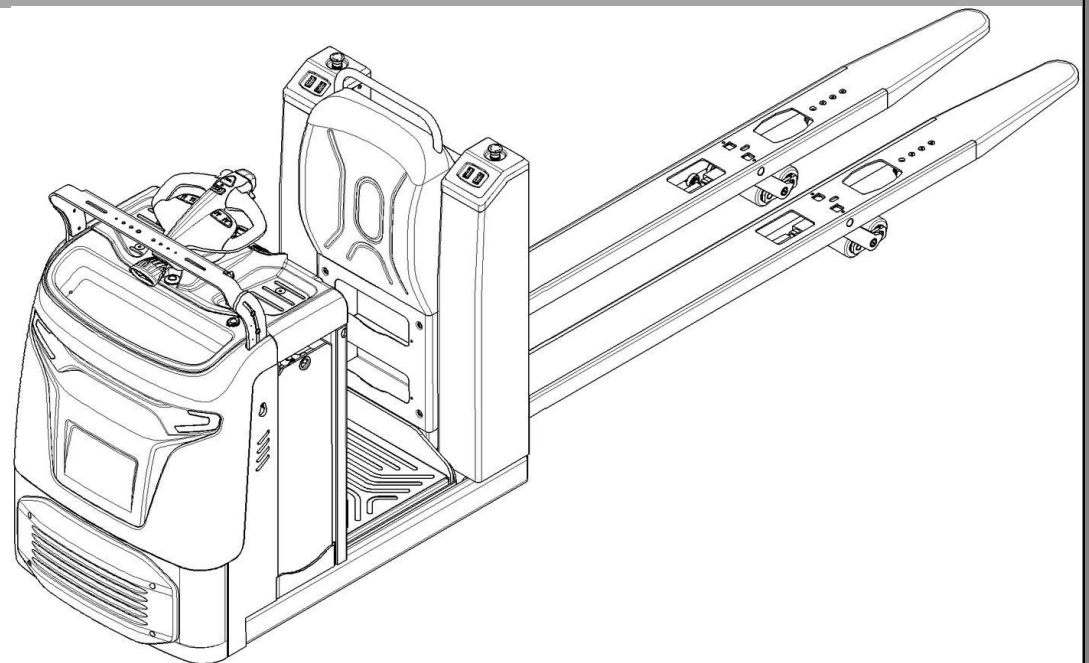

INSTRUCTION MANUAL

Low-lift Order Picker



WARNING

Do not operate the tow order picker before reading and understanding the operating instructions.

NOTE:

- **Please check product type and parameters of your truck in this manual as well as on the ID-plate.**
- **Keep this instruction manual for future reference.**

FOREWORD

Before operating the order picker, please read this instruction manual carefully and understand the usage of the truck completely. All instructions in this manual should be seriously followed, otherwise warranty will be invalid by default, and our company shall not be liable for any losses arising therefrom.

If the customer or a third party modifies the order picker without manufacturer's permission, the warranty will be invalid by default, and our company shall not be liable for any loss arising therefrom.

This manual describes the usage of different stand-on order pickers. When operating and servicing the order picker, make sure that it applies to your truck type.

Our products are subject to ongoing developments, so the company reserves the right to modify the appearance, configuration and function of the products, therefore please have understanding, that any claims on performance shall not be derived from this manual.



Chapter 11 describes specialized stipulations and regulations for the American market. Follow these instructions and stipulations if you operate the truck within the American market!

Keep this manual for future reference. If this manual and the warning/ caution stickers are damaged or got lost, please contact your local dealer for replacement.

This order picker complies with the requirements according to EN 3691-1 (Industrial trucks- safety requirements and verification, part 1), EN 12895 (Industrial trucks- electromagnetic compatibility), EN 12053 (Safety of industrial trucks- test methods for measuring noise emissions), EN 1175 (Industrial truck safety—electrical requirements), ensured the truck is used according to the described purpose.

The noise level for this machine is 70 dB(A) according to EN 12053.

The vibration is 0.96 m/s² according to EN 13059.

ATTENTION:

- Environmentally hazardous waste, such as batteries, oil and electronics, will have a negative effect on the environment, or health, if handled incorrectly.
- The waste packages should be sorted and put into solid dustbins according to the materials and be collected disposal by local special environment protection bureau. To avoid pollution, it's forbidden to throw away the wastes randomly.
- To avoid leaking during the use of the products, the user should prepare some absorbable materials (scraps of wooden or dry duster cloth) to absorb the leaking oil in time. To avoid second pollution to the environment, the used absorbable materials should be handed in to special departments in terms of local authorities.
- Our products are subject to ongoing developments. Because this handbook is only for the purpose of

operating /servicing the pallet truck, therefore please have understanding, that there is no guarantee out of particular features out of this handbook.



NOTE: In this manual, the symbol on the left indicates warning and danger, which may lead to death or serious injury if not followed.

Copyright

The copyright remains with the company, mentioned on the CE- certificate at the end of this document or, if sold within the USA, with the company, mentioned on the company sticker.

TABLE OF CONTENTS

NOTE: In this manual, the symbol on the left indicates warning and danger, which may lead to death or serious injury if not followed.

NOTE: In this manual, the symbol on the left indicates warning and danger, which may lead to death or serious injury if not followed.	2
1. CORRECT APPLICATION	4
2. DESCRIPTION OF THE ORDER PICKER	5
a. Definition of directions	5
b. Overview of the main parts	6
c. Main technical data	7
d. Description of the safety devices and warning stickers (Europe and other, excepting USA)	9
e. Identification plate (ID plate)	9
3. WARNINGS, RESIDUAL RISK AND SAFETY INSTRUCTIONS	10
4. COMMISSIONING, TRANSPORTING, DECOMMISSIONING	10
a. Commissioning	10
b. Lift/ transportation	11
c. Decommissioning	11
5. DAILY INSPECTION	12
6. OPERATING INSTRUCTIONS	12
a. Pin-code lock Settings	12
b. Starting	13
c. Driving	13
d. Lifting	14
e. Lowering	14
f. Steering	15
g. Braking	15
h. Parking	15
i. Malfunctions	15
j. Emergency	15
7. BATTERY MAINTENANCE, CHARGING AND REPLACEMENT	16
a. Maintenance	16
b. Charging	16
c. Replacement	17
d. Battery indicator	17
8. REGULAR MAINTENANCE	17
a. Maintenance checklist	18
b. Lubricating points	19
c. Check and refill hydraulic oil	19
d. Checking electrical components and fuses	20
9. TROUBLE SHOOTING	21
10. WIRING/ CIRCUIT DIAGRAM	22
a. Electrical circuit diagram	22
b. Hydraulic circuit	23
11. SPECIALIZED STIPULATIONS FOR AMERICAN MARKET	24
a. Foreword/ Compliance	24
b. Description warning labels (only USA market)	25
12. DECLARATION OF CONFORMITY (valid if sold within EU area)	27
[GB] CE Declaration of Conformity	27
[D] EG-KONFORMITÄTSEKTLÄRUNG	27
[NL] EG-CONFORMITEITSVERKLARING	27

1. CORRECT APPLICATION

The order picker described in this manual is standing low-lift order picker , which possess functions such as: electrically powered low lift of forks, electrically powered lift of man-up platform (optional), electrically powered walking and steering, and electromagnetic braking.

It is only allowed to use the order picker following the instructions of this manual. Improper usage will cause human injuries or damage to the equipment. Meanwhile, the operator/ the operating company has to ensure the correct usage and has to ensure, that this order picker is used only by staff, who is trained and authorized to use this order picker.

The operator must pay attention to the information on the warning stickers, safety instructions and ID plate on the truck to ensure the proper usage.

The order picker has to be used on substantially firm, smooth, prepared, level and adequate surfaces.

The order picker should be operated with ambient temperatures between +5°C to + 40°C.

The order picker is intended to be used indoors with 50Lux operating lighting at least.

Pushing or pulling the loads by forks or the truck body is not allowed.

Operating sideways or diagonally on ramps is not allowed. Keep the forks upwards when going up or down the ramps.

Lifting or transporting people is not allowed.

The order picker is not allowed to be used in an area with explosion hazard.

The order picker is not allowed to be used outdoors in bad weather.

The order picker is not allowed to be used in a dusty or corrosive environment, unless it equips with special protective assembly approved by manufacturer.

No modifications or changes to this order picker which may affect rated traction capacity, stability or safety requirements of the order picker shall be made without the prior written approval of the original order picker manufacturer, its authorized representative, or a successor thereof. This includes changes affecting, for example, braking, steering, truck weight and the increase/ decrease of removable accessories. When the manufacturer or its successor approve a modification or change, they shall also make and approve appropriate changes to ID plate, operation and maintenance manuals.

Obeying these instructions will make the warranty invalid.

2. DESCRIPTION OF THE ORDER PICKER

a. Definition of directions

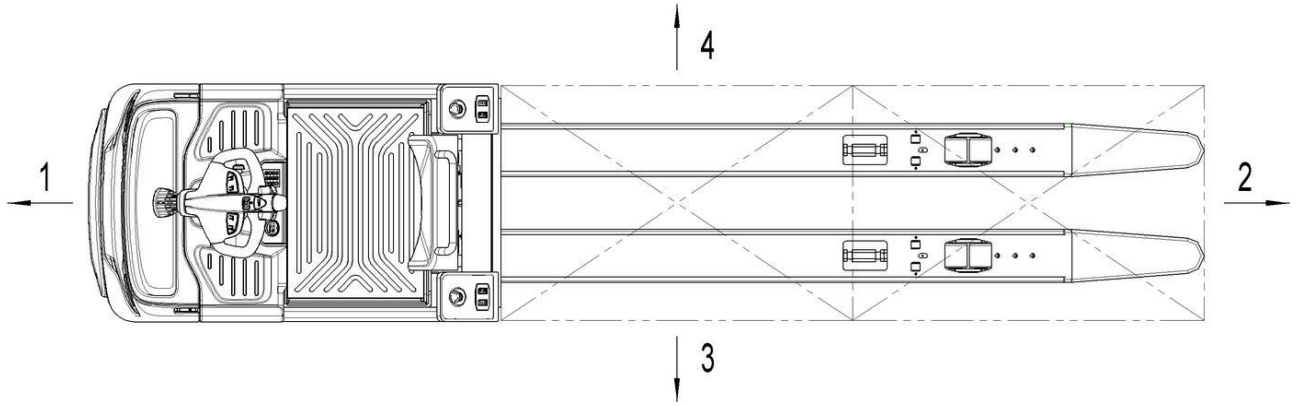

No.	Definition of directions	Note
1	Front	Driving side
2	Rear	Loading side
3	Left	
4	Right	

b. Overview of the main parts

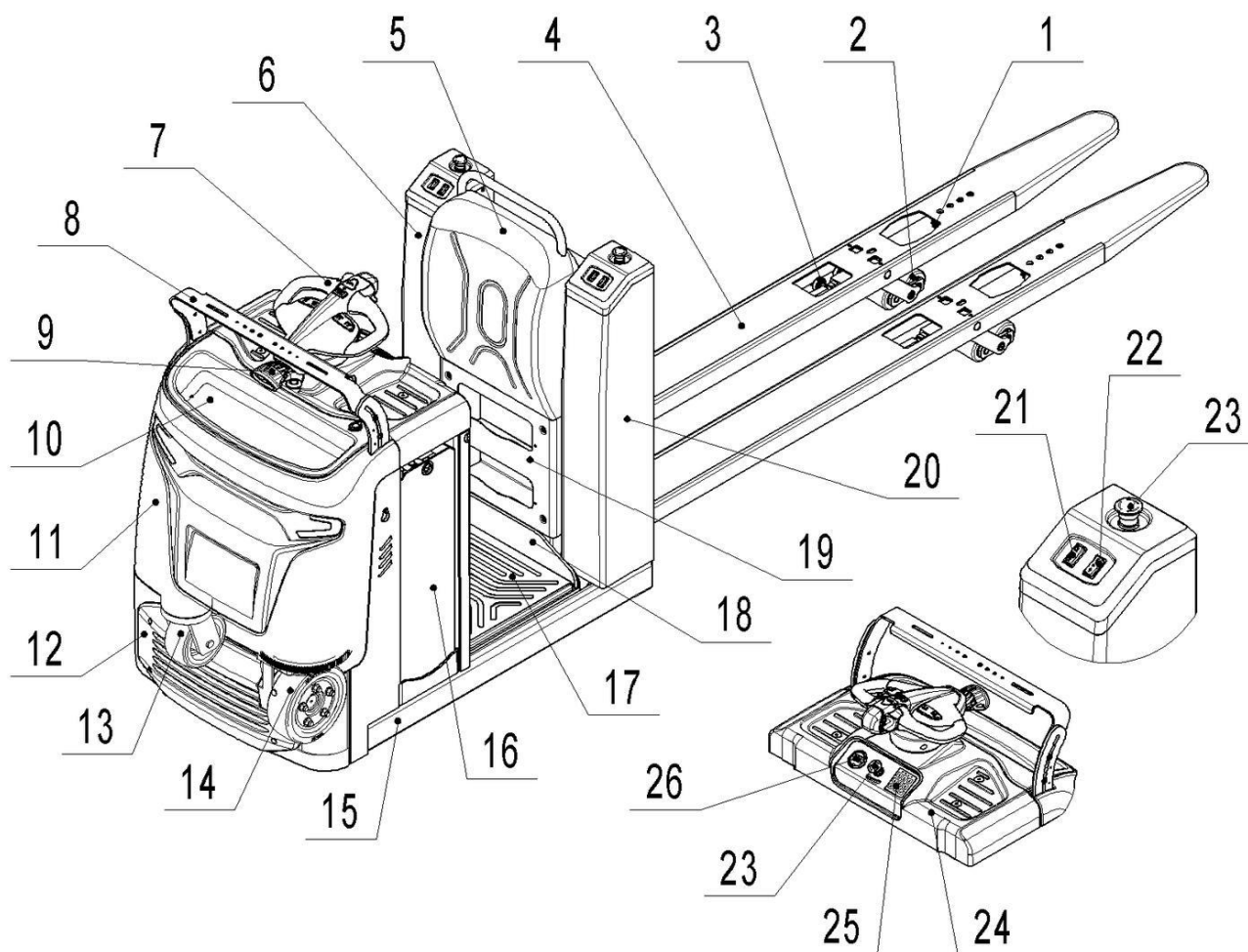

No.		Description	No.		Description
1	○	Entry-roller	15	●	Chassis
2	●	Tandem load wheels	16	●	Lead-acid battery
	○	Single load wheel		○	Lithium battery
3	○	Exit-roller	17	●	Rubber mat
4	●	Fork	18	●	Platform
5	●	Backrest		○	Platform (man-up)
6	●	Right cover	19	●	Storage compartment
7	●	Tiller		○	Fender
8	●	Accessory bar	20	●	Left cover
9	●	Blue-ray light	21	●	Sideways control (FW./ BW.)
10	●	Storage compartment	22	●	Sideways control (lift/ lower)
11	●	Front cover	23	●	Emergency button
12	●	Bumper	24	●	Upper panel
13	●	Side roller	25	●	Pin-code lock
14	●	Drive wheel	26	●	Indicator
		●: Standard	○: Optional		

C. Main technical data

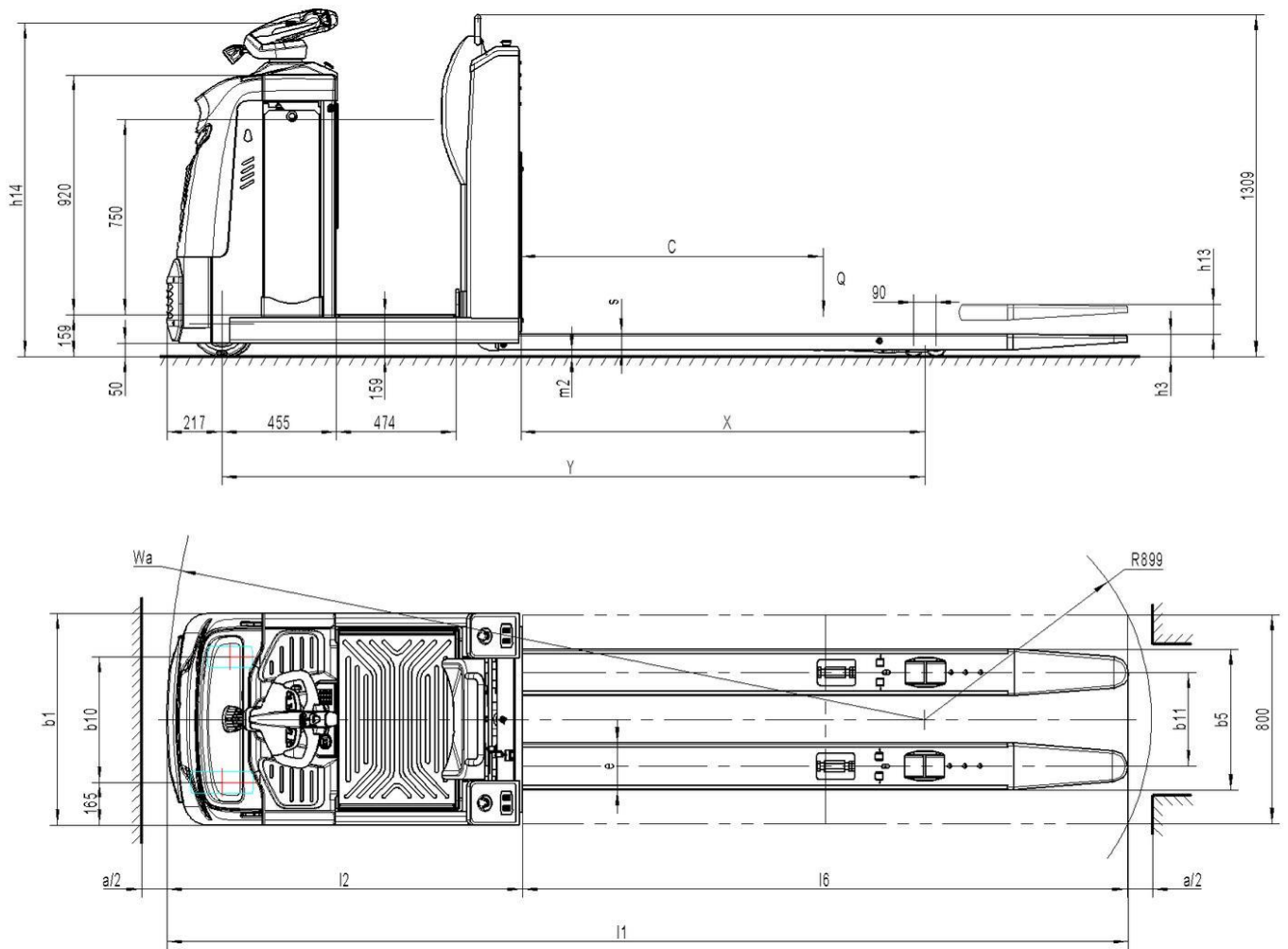

Type sheet for industrial order picker according to VDI 2198

Type sheet for industrial order picker according to VDI 2198				
Identification	1.2	Model		OPL25N
	1.3	Drive		Electric
	1.4	Manual, pedestrian, stand-on, seated, order picker operation		Order pickers
	1.5	Load capacity/rated load	Q(kg)	2500
	1.6	Load centre distance	C(mm)	1200
	1.8	Load distance	X(mm)	1535 ¹⁾
	1.9	Wheelbase	Y(mm)	2723 ¹⁾
Weights	2.1	Net weight without battery	kg	968
	2.2	Axle loading, laden front/rear	kg	1290/2530
	2.3	Axle loading, unladen front/rear	kg	980/340
Wheels/frame	3.1	Tyres		PU
	3.2	Tyre size, front	Ø x w (mm)	Ø250×80
	3.3	Tyre size, rear	Ø x w (mm)	Ø82×82
	3.4	Additional wheels(dimensions)	Ø x w (mm)	Ø180×80
	3.5	Wheels, number front/rear(x=driven wheels)		1+1x/4
	3.6	Tread width, front	b ₁₀ (mm)	480
	3.7	Tread, width, rear	b ₁₁ (mm)	360

Basic dimensions	4.4	Lift	h_3 (mm)	115
	4.9	Height of tiller	h_{14} (mm)	1280
	4.15	Height,lowered	h_{13} (mm)	85
	4.19	Overall length	l_1 (mm)	3770 ²⁾
	4.20	Length to face of forks	l_2 (mm)	1370 ²⁾
	4.21	Overall width	b_1 (mm)	810
	4.22	Fork dimensions	s/e/l	60/180/2400
	4.25	Width across forks	b_5 (mm)	540
	4.32	Ground clearance(centre of wheelbase)	m_2 (mm)	25
	4.34	Aisle width for pallets 800×1200 lengthways	Ast(mm)	3970 ³⁾⁴⁾
	4.35	Turning radius	Wa (mm)	2965 ³⁾
Performance data	5.1	Travel speed laden/unladen	km/h	9/12
	5.2	Lift speed,laden/unladen	mm/s	40/64
	5.3	Lowering speed,laden/unladen	mm/s	60/40
	5.8	Max. gradeability,laden/unladen	%	6/12
	5.10	Service brake		regenerative
Electric	6.1	Drive motor,output at S2 60min	kW	2.6
	6.2	Lift motor,output at S3 10%	kW	2.2
	6.3	Battery as per DIN 43531/35/36 A, B, C, no		no
	6.4	Battery voltage/nominal capacity K5	V/Ah	24/465
	6.5	Battery weight	kg	352
	6.6	Energy consumption as per EN 16796	kWh/h	0.7
Misc.	8.1	Type of drive control		AC-speed control
	8.4	Sound pressure level at operator's ear as per EN12053	dB(A)	<70
	8.6	Steering		Electric steering

1) Forks lowered X=1600mm, Y=2788mm;

2) With bumper $l_1=3810$ mm, $l_2=1409$;

2) With bumper Wa=3005mm, Ast=4010mm

4) Diagonal calculation acc. to VDI2198: Ast=initial value+94mm

d. Description of the safety devices and warning stickers (Europe and other, excepting USA)



For the USA market, the description of the safety and warning labels is mentioned in chapter 11.

- A Capacity sticker
- B Identification plate (ID plate)
- C Crane hook sticker
- D Hydraulic oil adding sticker

The order picker is equipped with 3 emergency buttons (23), pressing any one of the three buttons can turn off all the functions of the order picker .

The tiller of this order picker is equipped with a safety (belly) button (27), which switches the driving function away from the operator, if the order picker travels towards the operator and the tiller is activated in the tiller's operating position.

Follow also the instructions given on the stickers.
Replace the stickers if they are damaged or missing.

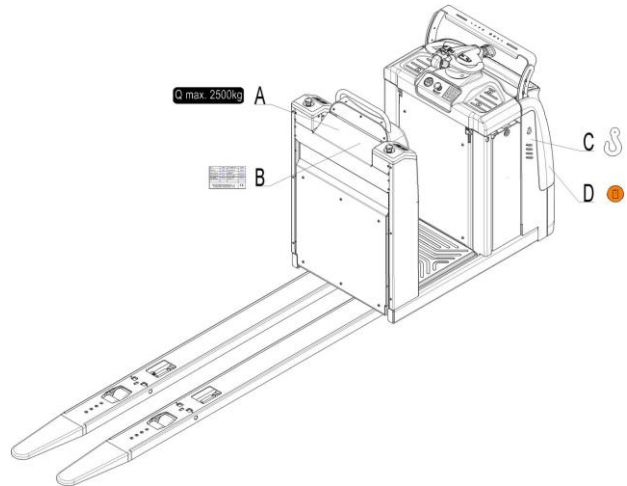

e. Identification plate (ID plate)

Type	XXXX	Fork dimensions	XXXX
Serial No.	XXXX	Year of Manuf.	XXXX
Rated capacity	XXX kg	Load center distance	XXX mm
System voltage	XX V	Nominal power	XXX kW
Net weight without battery	XXX kg	Battery mass min/max	XXX kg
XXXXXXXXXX XXXXXXXXXX			CE

3. WARNINGS, RESIDUAL RISK AND SAFETY INSTRUCTIONS



DO NOT

- Operate the order picker without safety shoes.
- Place your feet or hands under the order picker.
- Allow other person than the operator to stand in front of or behind the order picker when it is moving.
- Overload the order picker.
- Lift people. People could fall down and suffer severe injury.
- Push or pull loads.
- Drive laterally or diagonally on ramps.
- Load the loads unevenly, loads must be evenly distributed on two forks.
- Load the order picker with unstable and unbalanced loads.
- Refit the order picker without manufacturer's written consent.
- Lift the heavy loads or big loads in the case of wind influence.

If the working ground is not smooth or firm, the loads may slip off or the order picker may lose control when driving. Therefore, please check the working conditions before driving. When driving on the undesired working ground, please always keep an eye on the loads. Stop operating the order picker if the loads become unstable.

This order picker is not designed to be water-resistant, do not operate it outdoors in rainy days. If the order picker has malfunctions, check chapter 6 for details.

4. COMMISSIONING, TRANSPORTING, DECOMMISSIONING

a. Commissioning

Type	OPL25N
Commissioning weight [kg]	Around 1400
Dimension [mm]	3800X840X1500

After receiving the new order picker or for re-commissioning, you have to do followings before (firstly) operating the order picker:

- Check if all parts are included and not damaged.
- Check if all functions of the tiller work normally.
- Check if proper batteries and chargers are used.
- Check the hydraulic system for oil leakage.
- Do the work according to the daily inspections as well as functional checks.

b. Lift/ transportation

For transportation, remove the loads and lower the forks to the lowest position, use proper crane equipment or forklift to place the order picker on the vehicle or other equipment for transportation, and fix the order picker as required.

Lift



The operation of loading and unloading to the order picker shall be carried out only by personnel that has been trained in operation of fixing and lifting tools. Use specific cranes and lifting equipment. Equip yourself with protective equipment when the crane is working. Do not stand under rickety loads. Do not walk into a dangerous zone while lifting. Ensure that lifting tools will not damage the order picker during lifting.

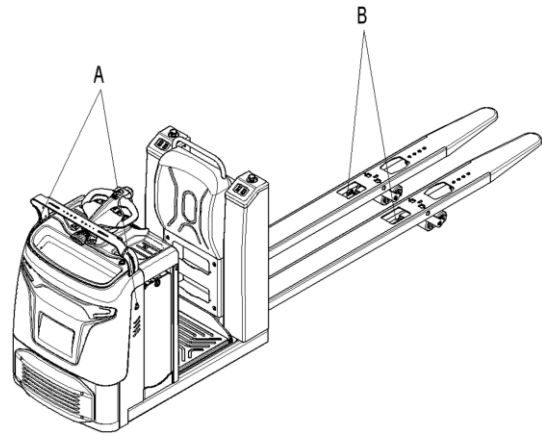

Safely park the order picker and remove the front cover. Fix the lifting tools to A and B of the truck.

Lift the order picker to the destination, place the order picker safely before moving the lifting equipment.

Transportation



During transportation on a lorry or truck always fasten the order picker securely. Fix the order picker with a wedge in case of accidental movement. The lashing band used should be strong enough. Fix the loading and unloading AIDS (pallets, wedges) with anti-slide materials.

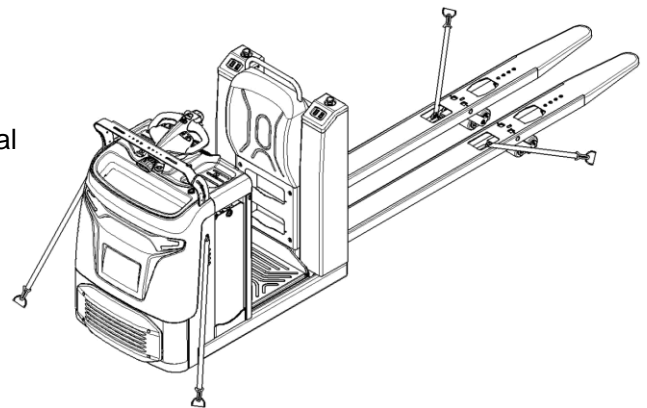

Lower the forks and park the truck securely.

Fasten the order picker with lashing band according to the picture on the right, find the proper location for the lashing band.

Or fasten the order picker via the man-up platform with lashing band.

c. Decommissioning

For storage, remove the loads, lower the forks to the lowest position, grease all parts listed in this manual (regular inspection), eventual protect the order picker against corrosion and dust. Remove the battery from the order picker and check the safety devices and ensure Remove the battery and check the safety equipment to make sure there is no crush on the order picker.

For final decommissioning, hand the order picker to a designated recycling company. Oil, batteries and electric components must be recycled due to legal regulations.

5. DAILY INSPECTION

This chapter describes pre-checks before operating the order picker. Remove loads from order picker and lower the forks to the lowest position.

Daily inspection is effective to find the malfunctions or faults on this order picker. Check the following items before operation.



DO NOT USE THE order picker IF ANY MALFUNCTION IS FOUND.

- Check for scratches, deformation or cracks.
- Check if there is any oil leakage from the cylinder.
- Check the vertical creep of the order picker.
- Check the smooth movement of the wheels.
- Check the emergency braking function by activating the emergency button.
- Check the function of the proximity switch of the tiller.
- Check the lifting and lowering functions by operating the buttons.
- Check if all bolts and nuts are tightened firmly.
- Visual check if there are any broken hoses or broken electric wires.

6. OPERATING INSTRUCTIONS



ONLY PEOPLE TRAINED CAN OPERATE THE ORDER PICKER. BEFORE OPERATING THIS ORDER PICKER, PLEASE FOLLOW THE WARNINGS AND SAFETY INSTRUCTIONS (CHAPTER 3).

Operate the order picker with safety shoes.

Non-trained personnel are not allowed to operate and drive the order picker.

Lifting people is not allowed.

Stop operating immediately if any damages or defects are found, and report to the superior.

Modification or repair for the order picker without manufacturer's authorization is not allowed.

a. Pin-code lock Settings

The initial password of the pin-code lock is "1234", which should be changed after starting the order picker for the first time. New password should not be the same as the administrator password. Please consult your local dealer or call service hotline for the administrator password.

Pin-code lock supports additional ID cards, password entry, password modification and password reset.

Register additional ID cards: in standby mode, correctly enter the administrator password, press "√" button, the yellow indicator will flash, then enter "3" and press "√" button, the yellow indicator will continue flashing to enter the mode of registering additional ID card. At this time, put the additional ID card close to the pin-code lock and take it away. Press "x" button, the yellow

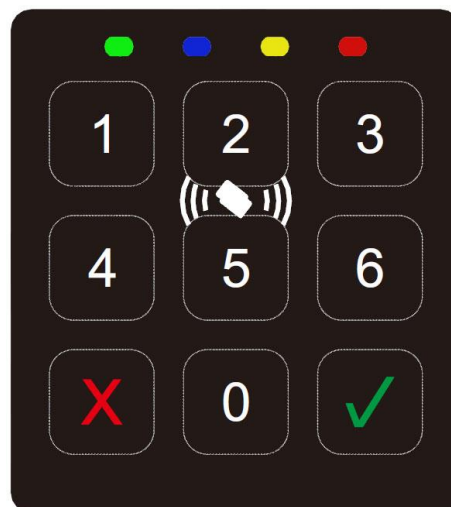

indicator will be off and exit the mode of registering additional ID card, or wait for 5 seconds after the card is successfully registered, then the system will exit the current mode automatically.

Password entry: in standby mode, correctly enter the administrator password, press "√" button, the yellow light will flash, and then press "1" and "√" button, the yellow indicator will continue flashing to enter the mode of password entry. At this time, enter a 4-digit-code in turn and press "√" button, the password entry is successfully done if the buzzer rings once. Pin-code lock can support up to 10 sets of passwords. After recording 10 sets of passwords, the newly entered passwords will be overwritten one by one from the first set, please save the passwords that have been set.

Password modification: in standby mode, correctly enter the administrator password and press "√" button, the yellow indicator starts flashing. Then press "2" button and "√" button, the yellow indicator continues flashing and entering the password modification mode. Enter the initial password and press "√" button, the buzzer will ring once. Then enter new password and press "√" button, after the one-time ring of the buzzer, the yellow indicator will be off and the password is successfully modified.

Password reset: in standby mode, correctly enter the administrator password and press "√" button, the yellow indicator starts flashing, and then press "0" button. The buzzer will ring once, which indicates that the passwords set by users are cleared and reset as initial password "1234".

As shown in the figure above, the four indicators on the pin-code lock are green indicator (power), blue indicator (working), yellow indicator (waiting) and red indicator (error).

b. Starting

After completing daily inspection, turn on emergency button (23) to make the order picker connected to the power and standby. Enter the correct password and press "√" button and the buzzer rings once, the green indicator turns on and the order picker is successfully started. Or put ID card close to the pin-code lock, after buzzer rings once, the green indicator is on and the order picker is successfully started. Before starting the order picker, check if there is safety hazard around the order picker, and then press the horn button (32) to send out the warning signal of the working order picker.

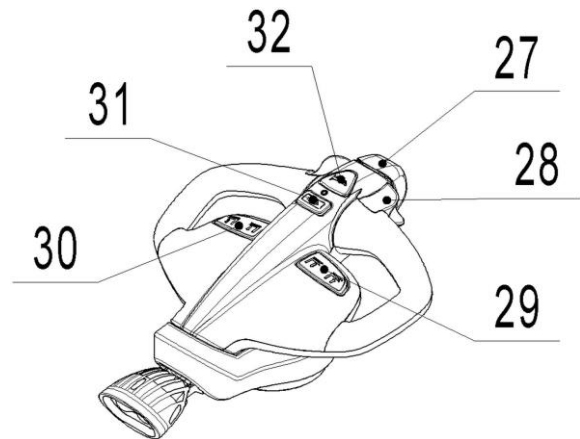

c. Driving



TRAVEL ON INCLINES ONLY WITH THE LOAD FACING UPHILL.
DO NOT TRAVEL ON INCLINES MORE THAN SPECIFIED WITH THE TECHNICAL DATA.

Turn the accelerator button to the desired direction forward 'Fw.' or backwards 'Bw.'. Carefully operate

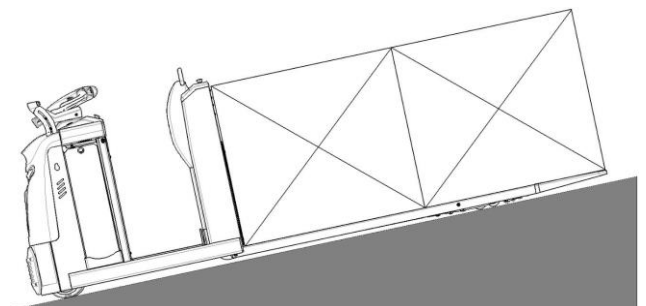

the accelerator knob (28) to control the driving speed to the desired speed. If the accelerator knob is back to the neutral position, the controller will slow the order picker until it stops. If the order picker stops, the parking brake will work.

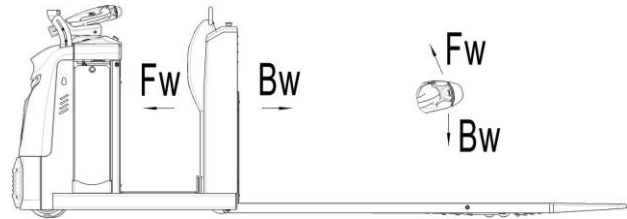

Please carefully drive the order picker to your destination, watch the route conditions and adjust the driving speed via the accelerator knob operation.

Press "turtle speed" button (31) to activate the turtle speed function. The indicator turns red and the maximum speed of the order picker decreases; When press turtle button (31) again, the turtle speed function is closed, the indicator turns green and the maximum speed of the order picker will be decreased to the initial speed.

d. Lifting



A single pallet with a load of up to 1250kg can be placed behind the forks.

A single pallet with a load of more than 1250kg shall have its center of gravity coincident with the load centre of the order picker in vertical direction. The loads shall not exceed the tip of the forks by more than 50mm.

Do not overload, the rated capacity of this order picker is 2500kg, and the rated capacity of the load generally is not equal to the allowable loads. Damage to the order picker or deformation of the fork caused by not handling the loads as required will make the warranty invalid.

Lower the forks to the lowest position and move the forks to proper position under the loads. Press lift button (29)/(30) until proper height is reached.

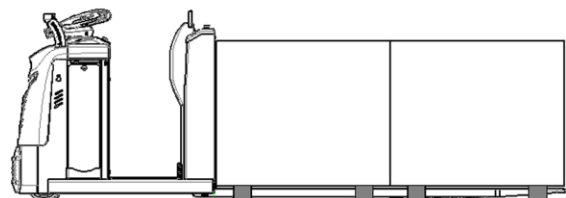
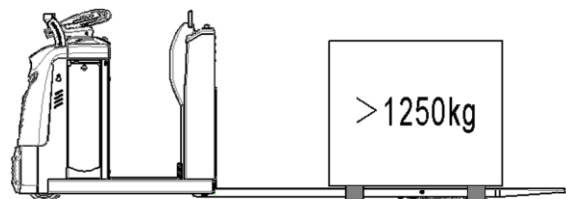
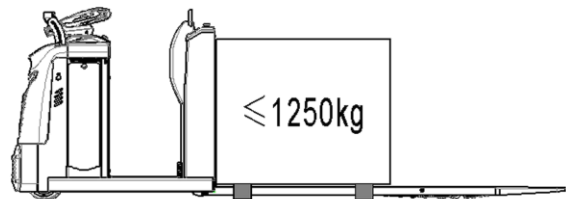

In picking mode, forks can be lifted by operating sideways control (22).

If the platform can be lifted, the lift button (30) on the tiller can control the lifting of the platform, and the lift button (29) on the tiller can control the lifting of the forks.

e. Lowering



Operator should be in correct position before lowering the forks. Do not place your hands and feet under the forks or order picker.

Press lowering button (29) or (30) and the forks will be lowered.

If the platform can be lifted, the lift button (30) on the tiller can

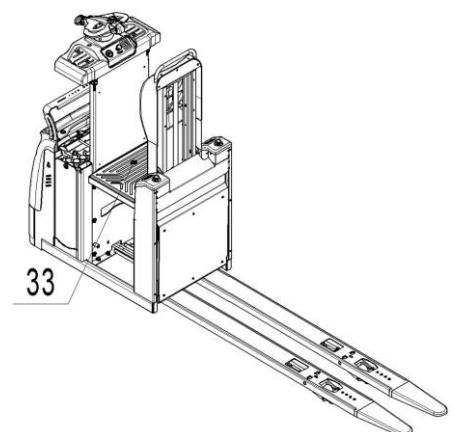

control the lowering of the platform, and the lift button (29) on the tiller can control the lowering of the forks.

In picking mode, forks can be lowered by operating sideways control (22).

Stomp the pedal switch (33) twice quickly and hold on, the platform can be lowered by this way. The platform stops lowering if the pedal switch (33) is released.

f. Steering

Steer the order picker by moving the tiller (7) to left/ right side. Left/ right rotation limit of the tiller is 60° , corresponds to the 90° left/ right rotation limit of the drive wheel.

If you steer the tiller when driving the order picker, the speed of the order picker will be gradually decreased with the increase of steering angle.

g. Braking



Braking performance depends on the conditions of the road, loads and speed of the order picker. The braking function can be activated by several ways below:

- Operate the accelerator knob (28) back to the neutral position or release the accelerator knob, the regenerative braking is activated. The order picker brakes until it stops.
- Operate the accelerator knob (28) from one driving direction directly to the opposite direction, the regenerative braking is activated and the order picker starts driving into the opposite direction.
- Activate safety (belly) button (27), the order picker decelerates the truck in opposite direction until the order picker stops.

h. Parking



Do not park the order picker when on ramps.

Operators are not allowed to leave the order picker for a long time without power supply

Park the order picker on firm and level ground.

Press emergency switch (23) if the operator is to leave the order picker for a long time.

i. Malfunctions

If there are any malfunctions or the order picker is inoperative, please stop using the order picker and press the emergency button (23). If possible, park the order picker on a safe area.

Inform immediately the manager and, or call for after-sales service. If necessary, tow the truck out of the operating area by using specific towing/ crane equipment.

j. Emergency

If emergency button (23) is pressed during driving operation, the order picker will be stopped with maximum braking power, so the loads may drop off from the order picker or trailer, so emergency button

(23) cannot be used as the brake during driving.

Emergency button (23) can only be used under dangerous conditions during driving.

If emergency switch is damaged or out of reach, there will be risk of accidents.

7. BATTERY MAINTENANCE, CHARGING AND REPLACEMENT



- Only trained technicians are allowed to maintain, charge or replace the battery.
- Recycling of batteries undergoes national regulations. Please follow these regulations.
- Protect batteries away from open fire for battery disposal, otherwise it will cause explosion.
- Smoking and open fire is not allowed around the battery. Keep the inflammable materials or equipment that is easily catching sparkles 2m away from the charging place. And the charging place must be ventilated and equips with fire extinguishers.
- Before finishing the maintenance work, make sure, that all cables are connected correctly and that there are no disturbing towards other components of the order picker.



The weight of the battery has great influence on safety, stability and load capacity of order picker. Please consider the maximum operating temperature of the battery and check the battery manufacturer's manual for details.

If the order picker equips with lithium battery, please follow the lithium battery manual to maintain, charge and replace the battery.

a. Maintenance

Lead-acid battery terminals, cable terminals and battery caps must be fasten and clean, and properly grease these parts.

- For normal operation, add water once every 2 weeks; under high temperature or high intensity working conditions, add water once a week.
- Water should not exceed the maximum level.
- Better to add water in the last period of charging.
- Add deionized water (distilled water), do not add purified drinking water or acid liquid.
- Check details in the battery manual for other maintenance requirements.



b. Charging



- It is only allowed to use the supplied charger for charging the battery.
- The room where you are charging must be ventilated.
- Keep the inflammable materials or explosive articles 2m away from the charging place.

Park the order picker securely and switch off the order picker with pressing the emergency button (23). Press lock catch (34) and lift the tiller (7) to open the console. Unplug the battery connector (37) and connect it to the charger for charging. Battery assembling is in the opposite order.

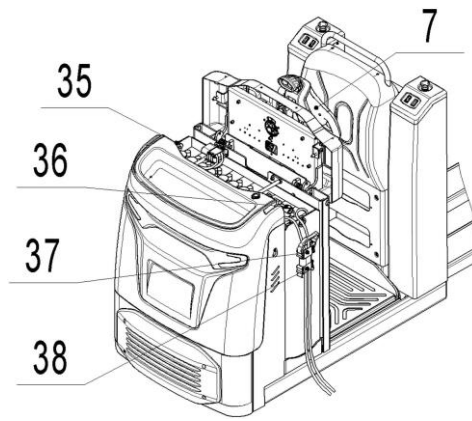
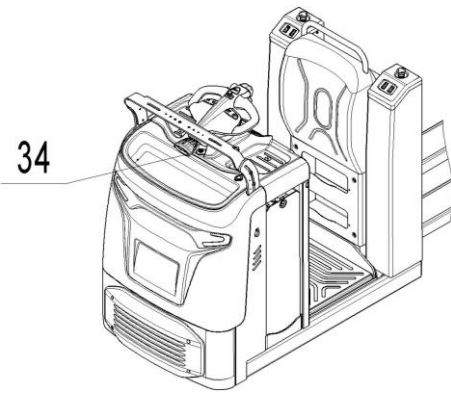

c. Replacement

Take out the battery and place it on the equipment for battery replacement safely, and ensures that the battery replacement device does not move during the battery replacement.

Incorrect use of the device may cause the battery being tipped over!

To remove the battery, press lock catch (34) and lift the tiller (7) to open the console. Flip the pad (35), loosen the battery lock lever (36) and turn it over, then remove battery from the side of the order picker. Battery assembling is in the opposite order.

d. Battery indicator

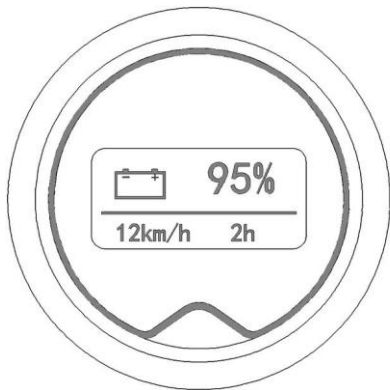

The left figure above shows the main interface of the indicator, which indicates the battery capacity, cumulative working hours and driving speed.

The right figure above shows the fault interface of the indicator, which indicates the fault code.

When the remaining battery power is 20%, it starts to flash.

When the remaining battery power is 10%, the lifting of the forks and the man-up platform is not allowed and the driving speed is reduced.

When the remaining battery power is more than 70%, the indicator shows the same value of battery power as the value before charging if the battery is charged.

Only when the remaining battery power is less than 70%, the indicator shows the correct value of battery power if the battery is charged.

8. REGULAR MAINTENANCE



- Only qualified and trained personnel are allowed to do maintenance on this truck.

- Before maintaining, remove the load from the forks and lower the forks to the lowest position.
- If you need to lift the order picker, please use the specific binding equipment or lifting equipment mentioned in Chapter 4. Before lifting the order picker, please put the safety device (for instance designated jack, wedge, or wooden blocks) under the order picker to avoid accidental fall, movement or sliding.
- Use approved and from your dealer released original spare parts.
- Please consider that oil leakage of hydraulic fluid can cause failures and accidents.
- It is allowed to adjust the pressure valve only from trained service technicians.

If you need to replace the wheel, please follow the instructions above. Casters must be round and free from abnormal wear.

Check the key items emphasized in the maintenance checklist.

a. Maintenance checklist

		Interval (Month)			
		1	3	6	12
Hydraulic system					
1	Check the hydraulic cylinder(s), piston for damage noise and leakage		•		
2	Check the hydraulic joints and hose for damage and leakage <input type="checkbox"/>		•		
3	Inspect the hydraulic oil level, refill if necessary		•		
4	Refill the hydraulic oil (12 month or 1500 working hours)				•
5	Check and adjust function of the hydraulic valve (2000kg +0/+10%)				•
Mechanical system					
6	Inspect the forks for deformation and cracks <input type="checkbox"/>		•		
7	Check the chassis for deformation and cracks		•		
8	Check if all screws are fixed		•		
9	Check the push rods for deformation and damages		•		
10	Check the gearbox for noise and leakage <input type="checkbox"/>		•		
11	Inspect the wheels for deformation and damages <input type="checkbox"/>		•		
12	Inspect and lubricate the steering bearing				•
13	Inspect and lubricate the pivot points		•		
14	Lubricate the grease nipples	•			
Electrical system					
15	Inspect the electric wiring for damage		•		
16	Check the electric connections and terminals		•		
17	Test the function of emergency button		•		
18	Check the electric drive motor for noise and damages		•		
19	Test the display		•		
20	Check, if correct fuses are used		•		
21	Test the warning signal		•		
22	Check the contactor(s)		•		
23	Check the frame leakage (insulation test)		•		
24	Check function and mechanical wear of the accelerator		•		
25	Check the electrical system of the drive motor		•		

Braking system				
26	Check brake performance, if necessary replace the brake disc or adjust the air gap		•	
Battery				
27	Check the battery voltage		•	
28	Clean and grease the terminals and check for corrosion and damage		•	
29	Check the battery housing for damages		•	
30	Check and if necessary refill the battery with distilled water	•		
Charger				
31	Check the main power cable for damages			•
32	Check the start-up protection during charging			•
Function				
33	Check the horn function	•		
34	Check the air gap of the electromagnetic brake	•		
35	Test the emergency braking	•		
36	Test the reverse and regenerative braking	•		
37	Test the safety (belly) button function	•		
38	Check the steering function	•		
39	Check the lifting and lowering function	•		
40	Check the stop button function	•		
General				
41	Check if all decals are legible and complete	•		
42	Inspect the castors, adjust the height or replace these if worn out.		•	
43	Carry out a test run	•		

b. Lubricating points

Lubricate the marked points according to the maintenance checklist. The required grease specification is: DIN 51825, standard grease.

- I . Load wheels
- II . Hydraulic system
- III . Gearbox

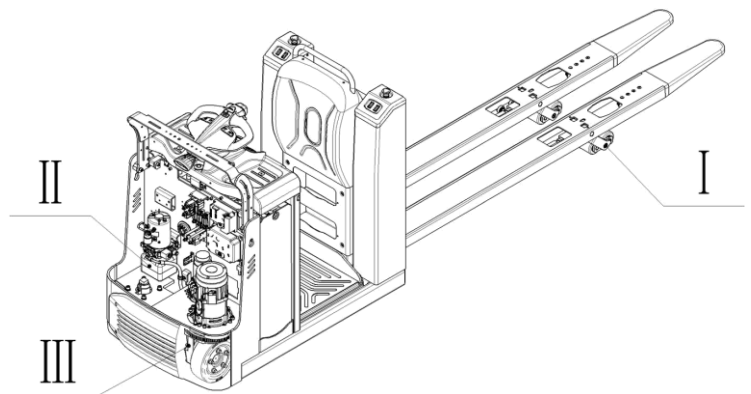

Waste material like used oil, waste batteries or others must be properly disposed and recycled according to the national regulations and if necessary brought to a recycling company.

The oil level in the oil tank should not be under the min marks for starting the order picker.

c. Check and refill hydraulic oil

The required hydraulic I type is:

- H-LP 46, DIN 51524
- Viscosity is 41.4 – 47
- Oil filling level: 1.5L for standard order picker, 3.0L for optional order picker with man-up platform

d. Checking electrical components and fuses

Remove the front panel, the fuses are located as shown in the following figure.

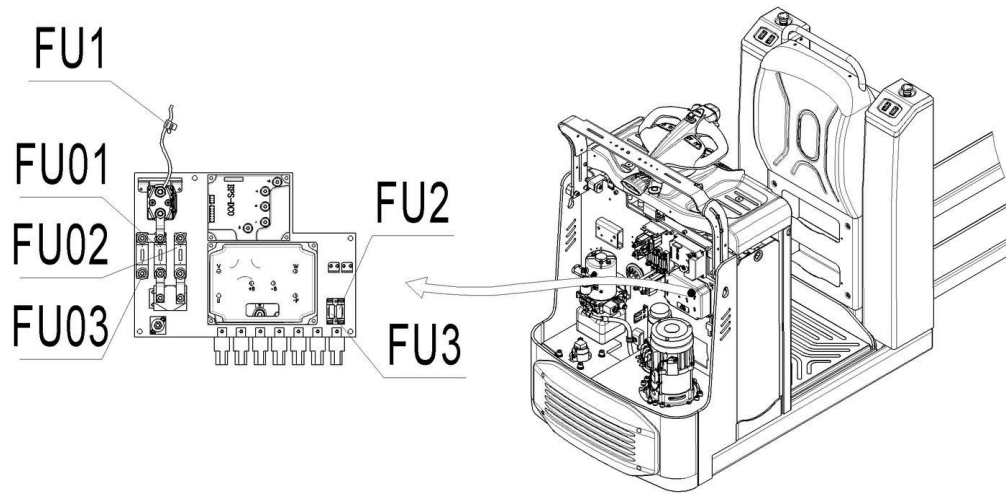

Fuse	Specification
FU1	10 A
FU2	10 A
FU3	15 A
FU01	350 A
FU02	30 A
FU03	200 A

9. TROUBLE SHOOTING

Fault	Possible cause	Solution
The truck cannot move	Battery connector is not connected well	Check and well-connected the connector
	The emergency switch is pressed	Release emergency switch
	The pin-code lock is not activated	Activate the pin-code lock
	Low battery	Check SOC and must charge the battery
	Protection device is damaged	Check the protection device
Low driving speed	SOC is under 10%	Charge the battery
	Turtle speed button is pressed	Release turtle speed button
	Man-up platform is lifted over 300mm	Lower Man-up platform until it is within 300mm
Loads cannot be lifted	Overload	Load the truck within rated capacity
	SOC is below 10%	Charge the battery
	Lifting fuse fault	Check and replace the lifting fuse
	Hydraulic oil level too low	Check and eventually refill hydraulic oil
	Oil leakage	Repair the hoses and/or sealing of the cylinder
	Proximity switch under the platform is damaged or not activated	Adjust or replace the proximity switch
Drive wheel slippage	Floor is not clean	Clean the floor
	Pits on the floor	Remove the trailer and drive out of the pit

If you are unable to troubleshoot the order picker after trying all the solutions listed above, contact your local dealer or our after-sales department, who will be responsible for further troubleshooting.

In order to find out the cause of the fault more accurately and quickly, please provide the following important information when you are to contact the local dealer or the after-sales department::

- Serial number of the truck (on the ID plate);
- Fault code on the indicator display;
- Description of the fault;
- The specific part of the order picker with fault;
- Contact details

10. WIRING/ CIRCUIT DIAGRAM

a. Electrical circuit diagram

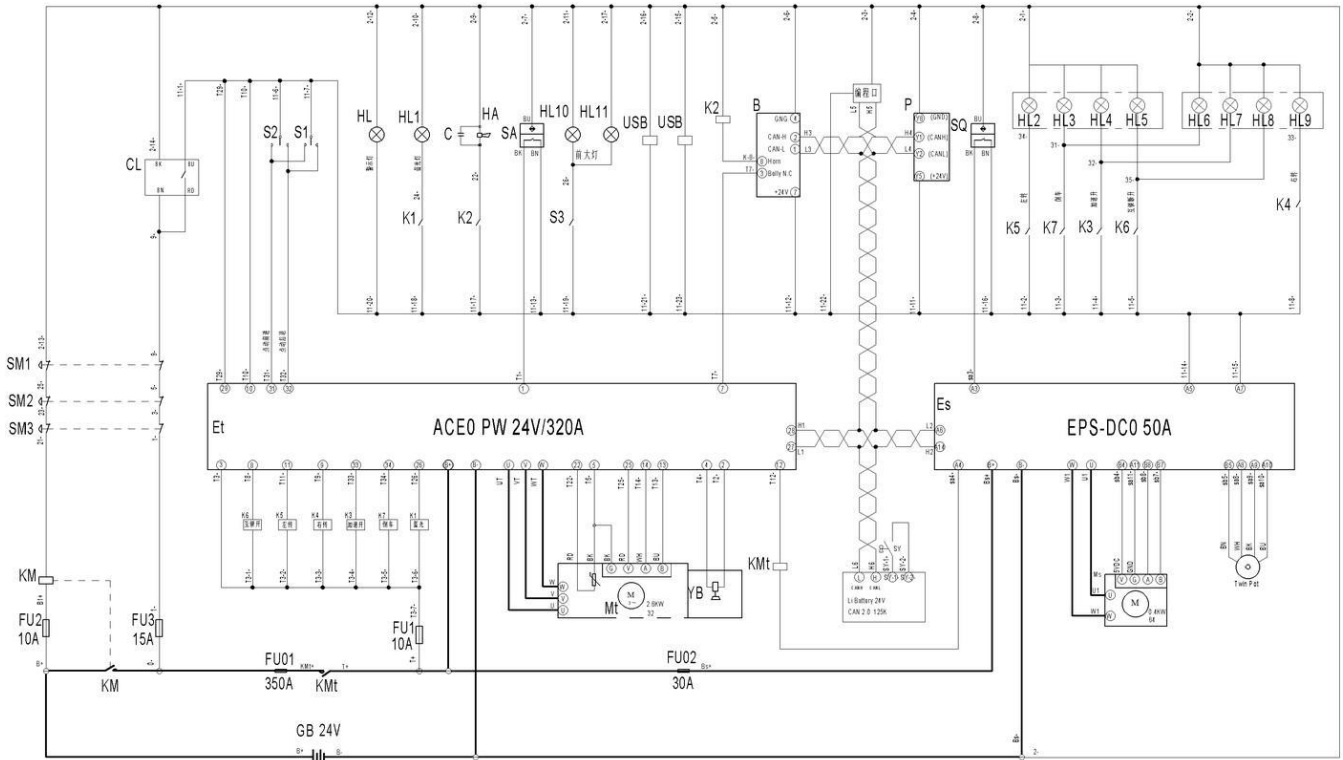

Code Description of Electrical Components:

No.	Code	Name	No.	Code	Name	No.	Code	Name	No.	Code	Name	No.	Code	Name		
1	GB	Battery	6	ES	Steering controller	13	C	Capacitance	18	SQ	Switch	24	HL2、HL3、 HL4、HL5、 HL6、HL7、 HL8、HL9	Tri-color Taillight		
2	SM1、SM2、SM3	Stop switch	7	Mt	Traction motor	14	S1、S2、S3	Switch	29	USB	USB		20	Ms	Steering motor	
3	FU01、FU02 FU1、FU2、 FU3	Fuse	8	YB	Elec. brake	15	HA	Horn	21	SA	Switch			22	HL10、HL11	Headlamp
	4		KM、Kmt	Main contactor	11	P	Instrument	17	K4、K5、K6、 K7	Relay	23				CL	Password lock
5	Et	Traction controller	12	B	Tiller											

b. Hydraulic circuit

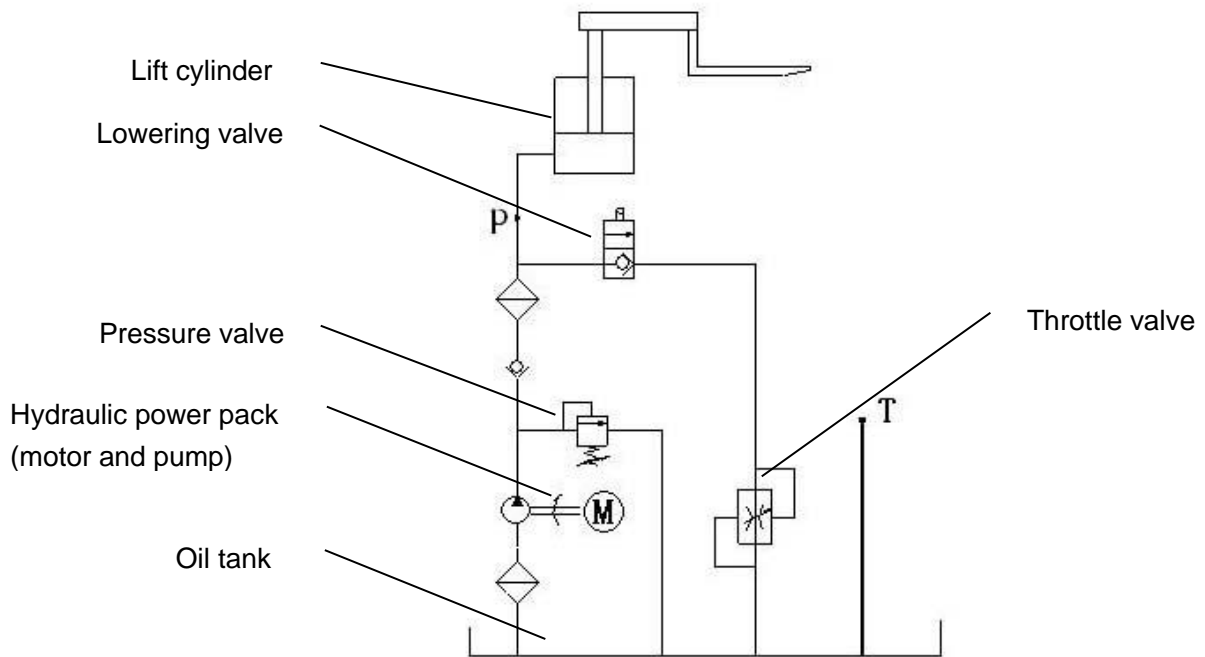

11. SPECIALIZED STIPULATIONS FOR AMERICAN MARKET

The content in this chapter is specialized for American market.

a. Foreword/ Compliance

Operating this truck requires knowledge which can be acquired from this instruction handbook. This manual must be kept available throughout the entire period of use of the industrial truck.

**IT IS LAW; YOU MUST BE TRAINED AND CERTIFIED TO OPERATE THIS TRUCK!
READ AND OBEY ALL WARNINGS AND INSTRUCTIONS IN THIS MANUAL AND ON
THE TRUCK!**

Only properly trained operators are allowed to operate a powered industrial truck. Your employer must train you and certify, that you are qualified to operate this truck (required by OSHA § 1910.178). Training must satisfy OSHA requirements and as minimum the topics mentioned in this manual. Depending on the context in this operating manual, the user can refer to several people, including the owner of the truck, anyone who leases or borrows this truck, and the operator as defined in ASME B56.1. Please pay attention to the section in ASME B56.1 concerning the operator. In this standard, it is defined that the safe operation is the responsibility of the operator (ASME B56.1-2003, Part II, section 5.1.1). You and others can be seriously injured or even killed if you don't use this truck correctly. Before operating your truck, inspect your truck and ensure that it is in correct working order. This truck was designed and built to current industry and government standards. For more information see following:

- ASME B56.1 (American Society of Mechanical Engineers)
- OSHA §1910.178 (Occupational Safety and Health Act)
- UL 583 (Underwriters Laboratory)
- ANSI Z535.4 (American National Standards Institute)

⚠ DANGER This sign indicates hazard situations, if not avoided, will result in serious injury or death. The instructions or precautions to this message must be observed to avoid the potential risk of injury or death.

⚠ WARNING If not followed, warning indicates hazard situations which may lead to moderate injury. The instructions or precautions to this message must be observed to avoid the potential risk of injury or death.

⚠ CAUTION If not followed, caution indicated situations which may lead to minor injury. Instructions or precautions must be observed to avoid minor injury.

b. Description warning labels (only USA market)

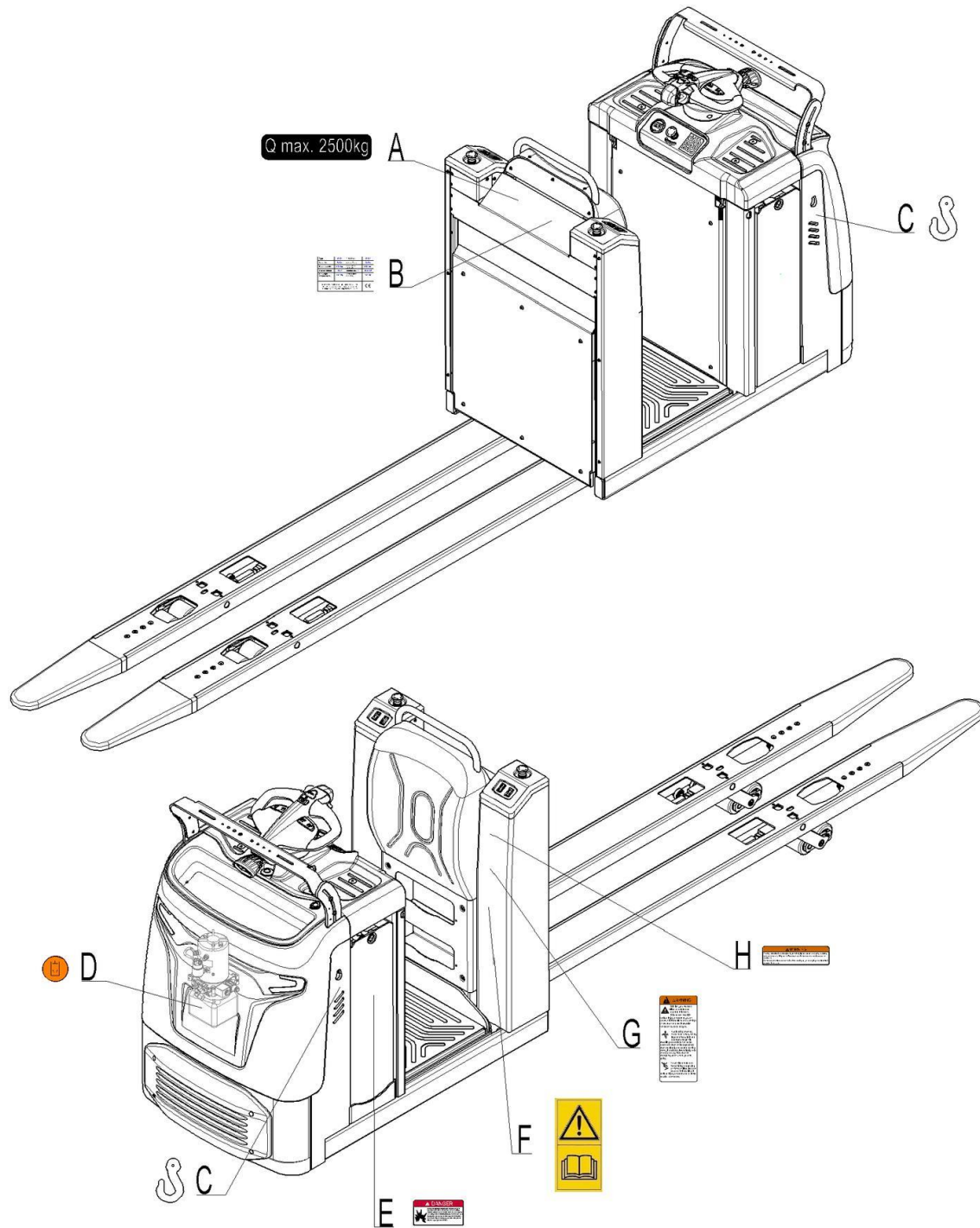

- | | | | |
|---|---------------------------------|---|------------------------------------|
| A | Capacity sticker | E | Sign danger battery |
| B | Identification plate (ID-plate) | F | Man-up label |
| C | Hook label | G | Sign warning stay clear stop truck |
| D | Sign oil filling point | H | Sign warning electrical devices |

The truck is equipped with three keys. The emergency button (23) can stop all lifting-, lowering-, driving-functions and engages the fail-safe electromagnetic brake when it is pressed. The function is described in chapter two. Follow the instructions given on the decals. Replace the decals if they are damaged or missing.

(B) Sign read and follow this instruction



(C) Sign oil filling point



(F) Sign warning stay clear stop truck

WARNING

 It is law, you must be certified and trained to operate this truck. Misuse can result in serious injury or death to you or others. All instructions and warnings on the truck and the instruction handbook must be obeyed.

 **Avoid being crushed.** Keep head, arms, hands, legs and feet within the operator area. While travelling be careful when parts extend the truck or its edges. Stop truck completely and set the parking brake, if equipped. Immediately exit and move away from truck in emergency. Look where you are going.

 **Never ride or stand on forks.** Riding or standing on forks or lifted load can cause a fall resulting in serious injury or death. Use extreme caution near docks.

(G) Sign danger battery

DANGER

 Batteries can produce explosive gas. Do not smoke, use open flame, or create an arc or sparks near this battery. Ventilate well when in an enclosed area and when charging. This battery contains Sulfuric Acid which cause severe burns. Do not get in eyes, on skin, or clothing. In case of contact, flush immediately and thoroughly with water. Get medical attention if your eyes are affected.

(H) Sign warning electrical devices

WARNING

 Adding electrical devices (radio, terminal, lights etc.) or changing existing components or wiring can affect truck performance and could cause an accident. Contact authorized personnel before adding to, or changing the electrical system in any way.

12. DECLARATION OF CONFORMITY (valid if sold within EU area)

CE-DD-002

[GB] CE Declaration of Conformity

The signatory hereby declares that the specified machine conforms to the EU Directive 2006/42/EC (Machine Directive) and 2014/30/EEC (Electro-Magnetic Compatibility, EMC) including their amendments as translated into national legislation of the member countries. The signatory is individually authorized to compile the technical documents.

[D] EG-KONFORMITÄTSEKTLÄRUNG

Der Unterzeichner bescheinigt hiermit, dass die im Einzelnen bezeichnete Maschine den Europäischen Richtlinien 2006/42/EG (Maschinenrichtlinie) und 2014/30/EWG (Elektromagnetische Verträglichkeit - EMV) einschließlich deren Änderungen sowie dem entsprechenden Rechtserlaß zur Umsetzung der Richtlinien in nationales Recht entspricht. Der Unterzeichner ist bevollmächtigt, die technischen Unterlagen zusammenzustellen.

[E] DECLARACIÓN DE CONFORMIDAD CE

El signatario certifica por medio de la presente que la máquina especificada cumple con las Normas Europeas 2006/42/CE (Normativa para maquinarias) y 2014/30/CE (Compatibilidad electromagnética), incluyendo sus respectivas modificaciones, así como con el decreto-ley para la adaptación de las normas al derecho nacional. El signatario dispone de una autorización individual que le permite compilar la documentación técnica.

[F] DECLARATION DE CONFORMITE CE

Par la présente déclaration, les soussignés certifient que le machines spécifié ci-dessus est conforme à la loi et aux directives européennes 2006/42/CE (directive sur les machines) et 2014/30/CEE (compatibilité électromagnétique - CEM), y compris aux modifications qui y sont apportées et à l'arrêté autorisant sa transposition en droit national. Chaque signataire est habilité à établir individuellement la documentation technique.

[NL] EG-CONFORMITEITSVERKLARING

Ondergetekenden verklaren hierbij dat - volgens de nationale wetgeving van de Lidstaten - de hierboven vermelde opgegeven machina beantwoordt aan de bepalingen qua veiligheid bij machines (EG richtlijn 2006/42/EC) en electro-magnetische compatibiliteit (EG richtlijn 2014/30/EEC). Ondergetekenden zijn ieder individueel gemachtigd het technisch dossier samen te stellen.

[P] DECLARAÇÃO DE CONFORMIDADE CE

Pela presente, os signatários certificam que o máquina especificado está conforme às Directivas Europeias 2006/42/CE („Máquinas“) e 2014/30/CEE („Inocuidade Electromagnética - IEM“), incluindo as alterações das mesmas e o respectivo decreto-lei para a transposição em lei nacional. Cada um dos signatários está autorizado a proceder à elaboração da documentação técnica.

[I] DICHIARAZIONE DI CONFORMITÀ CE

I sottoscritti dichiarano che il veicolo per trasporti interni a macchina specificato soddisfa le Direttive Europee 2006/42/EC (Direttiva Macchine) e 2014/30/EEC (Compatibilità elettromagnetica - EMV) comprese le relative modifiche, come pure il rispettivo decreto legislativo per la conversione delle direttive in diritto nazionale. I sottoscritti sono singolarmente autorizzati alla creazione della documentazione tecnica.

[BG] ЕВРОПЕЙСКА ОБЩНОСТ - ДЕКЛАРАЦИЯ ЗА СЪОТВЕТСТВИЕ

Подписаните удостоверяват с настоящето, че подробно описаното машина средство отговаря на европейския норматив 2006/42/EG (норматив за машини) и на 2014/30/EG (електро-магнетична съвместимост), включително с техните промени, както и на съответния указ за прилагане на нормативите в националното право. Подписаните при това са упълномощени поотделно да съставят техническата документация.

[CZ] EG - PROHLÁŠENÍ O SHODĚ

Níže podepsaný tímto potvrzuje, že podrobný popis uvedené stroje odpovídá Evropským směrnícím 2006/42/EC (směrnice pro stroje) a 2014/30/EEC (elektromagnetická interference - EMV) včetně jejich pozdějších úprav, jakož i příslušným právním výnosům pro uplatnění příslušné směrnice v rámci národního práva. Každý z podepsaných jsou jednotlivě způsobilí k vytvoření technických podkladů.

[DK] EF-OVERENSSTEMMELSESEKTLÆRING

Undertegnede attesterer hermed, at det specificerede maskine stemmer overens med de Europæiske Direktiver 2006/42/EU (maskindirektiv) og 2014/30/EØF (elektromagnetisk kompatibilitet - EMC) samt med den modsvarende lovvedtagelse til implementering af direktiver i den nationale lovgivning. De undertegnede er hver for sig beføjet til at sammenstille de tekniske dokumenter.

[EST] EL vastavusavaldus

Allakirjutatud tõendavad käesolevaga, et üksikasjaliselt kirjeldatud täpsustatud masin vastab Euroopa direktiividele 2006/42/EÜ (Direktiiv masinate kohta) ja 2014/30/EMÜ (Elektromagnetiline sobivus - EMS) kaasa arvatud nende muudatused ja nendele vastavatele õigusmäärustele direktiivide muutmiseks siseriiklikuks õiguseks. Iga allakirjutatu üksikult on volitatud koostama tehnilist dokumentatsiooni.

[FIN] EU-YHDENMUKAISUUSSELOSTUS

Allekirjoittaneet todistavat täten, että kukin erikseen mainittu omalla voimanolähteellä varustettu tehdaskone vastaa EU-direktiivien 2006/42/EC (koneenrakennusdirektiivi) ja 2014/30/EEC (sähkömagneettinen yhteensopivuus – EMC) määräyksiä sekä niiden muutoksia ja niiden kansalliseen lainsäädäntöön soveltamista koskevaa oikeussäätöä. Jokaisella allekirjoittaneista on oikeus itsenäisesti laatia asiaankuuluvia teknisiä asiakirjoja.

[GR] ΔΗΛΩΣΗ ΣΥΜΜΟΡΦΩΣΗΣ ΕΟΚ

Οι υπογράφωντες βεβαιώνουν διά της παρούσης ότι το συγκεκριμένο μηχάνημα συμμορφώνεται προς την Κοινοτική Οδηγία 2006/42/ΕΚ («Μηχανήματα») και 2014/30/ΕΟΚ (Ηλεκτρομαγνητικής Συμβατότητας, ΗΜΣ), καθώς και οι τροποποιήσεις τους, όπως μεταφράστηκε στην εθνική νομοθεσία των χωρών μελών. Οι υπογράφωντες είναι σε κάθε περίπτωση εξουσιοδοτημένοι ατομικά να καταρτίσουν τα τεχνικά έγγραφα.

[H] EU KONFORMITÁSI NYILATKOZAT

Alulírottak ezennel igazolják, hogy a részletesen leírt a megadott gép megfelel a 2006/42/EC (Gép-Írányelv) és a 2014/30/EEC (Elektromágneses összeférhetőség - EMV) Európai Irányelveknek, beleértve azok módosításait, valamint az irányelvek nemzeti jogba történő átültetésére irányuló megfelelő jogi rendelkezést. Továbbá az alulírottak mindegyike rendelkezik meghatalmazással arra nézve, hogy összeállíthatja a műszaki dokumentációt.

[LT] ES atitikimø deklaracija

Žemiau pasirašę asmenys patvirtina, kad atskirai aprašytas nurodyta mašina atitinka Europos Sąjungos direktyvas 2006/42/EB (Mašinų direktyva) ir 2014/30/EEB (Elektromagnetinis suderinamumas – EMS) įskaitant jų pakeitimus, o taip pat ir atitinkamą teisės aktą dėl direktyvų įgyvendinimo nacionalinėje teisėje. Kiekvienas iš pasirašusių asmenų turi teisę ruošti techninę dokumentaciją.

[LV] ES atbilstības deklarācija

Ar zemāk redzamajiem parakstiem tiek apliecināts, ka norādīts mašīna atbilst Eiropas Savienības normatīvām 2006/42/EG (Mašīnu normatīvas) un 2014/30/EGW (Elektromagnētiskā atbilstība – EMV), ieskaitot to izmaiņas, kā arī atbilstošos tiesiskos rīkojumus normatīvu pielāgošanai nacionālajā likumdošanā. Parakstu īpašnieki ir atsevišķi pilnvaroti sastādīt tehniskās dokumentācijas.

[N] EU-KONFORMITETSERKLÆRING

Undertegnede bekræfter hermed at de enkelte betegnede maskin med kraftdrift tilsvarende de europæiske retningslinjerne 2006/42/EC (maskinretningslinje) og 2014/30/EEC (elektromagnetisk fordraglighed - EMV) inklusiv disses endringer og den tilsvarende rettsforordning til omsetning av nasjonal rett. Hver undertegnede er fullmektig til å sette sammen de tekniske dokumentene.

[PL] DEKLARACJA ZGODNOŚCI WE

Niżej podpisani deklarują, że poniżej opisana maszyna spełnia wymagania określone w dyrektywach Europejskich 2006/42/EC (Dyrektywa Maszynowa) i 2014/30/EEC (Kompatybilności elektromagnetycznej - EMC) wraz z ich późniejszymi zmianami oraz odpowiednimi rozporządzeniami mającymi na celu przeniesienie tych dyrektyw do prawa krajów członkowskich. Sygnatariusz jest indywidualnie upoważniony do zestawiania dokumentacji technicznej.

[RO] DECLARAȚIE DE CONFORMITATE CE

Subsemnații adevăresc prin prezenta că vehiculul de specificat mașină descris individual corespunde directivelor europene 2006/42/CE (Directiva privind mașinile) și 2014/30/CEE (Compatibilitatea electromagnetică - CEM) inclusiv modificărilor lor precum și actului legislativ corespunzător pentru transpunerea directivelor în drept național. Subsemnații sunt fiecare în parte împuterniciți să întocmească documentația tehnică.

[RUS] Декларация соответствия стандартам ЕС

Настоящим лица, подписавшие документ, удостоверяют, что машина с указанной спецификацией соответствует европейским стандартам 2006/42/EG (Транспортная директива) и 2014/30/EGW (Электромагнитная совместимость - EMC), включая изменения в них, а также соответствующим национальным стандартам и нормам. Каждое по отдельности лицо, подписавшее документ, имеет полномочия для составления технической документации.

[S] EG-KONFORMITETSFÖRKLARING

Underteckarna intygar härmed att det i detalj betecknade maskin uppfyller de Europeiska direktiven 2006/42/EG (Maskindirektiv) och 2014/30/EEG (Elektromagnetisk tålighet - EMV), inklusive ändringarna i detta och den motsvarande rättsförordningen för att omsätta direktiven i nationell rätt. Underteckarna har var för sig fullmakt att sammanställa den tekniska dokumentationen.

[SK] vyhlásenie o zhode

Dolu podpísaní týmto potvrdzujeme, že podrobný popis uvedené stroje zodpovedá Európskym smerniciam 2006/42/EC (ernica pre stroje) a 2014/30/EGW (elektromagnetická tolerancia – EMV) vrátane jeho neskorších úprav, rovnako zodpovedá aj príslušným právnym nariadeniam na uplatnenie smerníc v rámci národného práva. Každý z podpísaných je jednotlivo splnomocnený na vytvorenie technických podkladov.

[SLO] EU IZJAVA O SKLADNOSTI

Podpisani s tem potrjujemo, da posamično označeno določeno stroj vozilo odgovarja Evropski direktivi 2006/42/EC (Direktiva o strojih) in 2014/30/EEC (Elektromagnetna skladnost - EMV) vključno z njihovimi spremembami ter ustrezno pravno uredbo o prevzemu smernic v nacionalno pravo. Podpisniki so vsakokrat posameznok pooblašteni za izdajanje tehnične dokumentacije.

[TR] AB Uygunluk Açıklaması

İmza sahibi şahıslar, ayrıntıları belirtilen makine aracının, 2006/42/EC (Makine Yönergesi) ve 2014/30/EEC (Elektromanyetik Uyumluluk – EMC) no'lu Avrupa Yönergelerine ve bunların değişiklik sonucu oluşan metinlerine ve yönergelerin milli hukuk hükümlerine dönüştürülmesine dair ilgili hukuk karamamesine uygun olduğunu tasdik ederler. İmza sahibi şahıslar teknik dosyaları bir araya getirmek için münferiden vekil tayin edildi.

- (1) Type/ Typ/ Tipo/ Modello/ Түппи/ Tipo / ΤΥΠΟΣ/ Τίπος/ Тип/ Тип/ Típs/ Tipas/ Tüüp:
- (2) Serial No./ Serien-Nr./ N°. de série/ Seriennummer/ N° de serie/ Numero di serie/ Serienr./ Sarjanro/ αυξάνων αριθμός/ Seriové číslo/ Szériaszám/ Nr.Seryjny/ Serijska številka/ Výrobné číslo/ Серийный номер/ Seri No./ Seerianr./ Sérijas Nr./ Serijos numeris:
- (3) Year of constr./ Baujahr/ Année de constr./ Bouwjaar/ Año de constr./ Anno di costruzione/ Produktionsår/ Byggeår/ Tillverkningsår/ Valmistusvuosi / Ano de fabrico / έτος κατασκευής/ Rok výroby/ Gyártási év/ Rokprodukcji / Letnik / Год изготовления / Üretim yılı / Văljalaskeaasta / Izgatavošanas gads / Gamybosmetai
- (4) Manufacturer or his authorized representative in Community/ Hersteller oder in der Gemeinschaft ansässiger Vertreter/ Fabricant ou son mandataire établi dans la Communauté/ Fabrikant of zijn in de Gemeenschap gevestigde gemachtigde/ Fabricante o representante establecido en la Comunidad/ Construtor ou Representante estabelecido na Comunidade/ Costruttore oppure il suo rappresentante nella Comunità/ Fabrikant eller dennesi Fællesskabet etablerede befuldmægtigede/ Produsent eller agent innen felleskapet/ Tillverkare eller representant inom EU/ Valmistaja tai yhteisömaassa oleva edustaja / V'robce nebo jeho zastoupení/ Gyártó / producunt albo jego przedstawiciel w EG (Wspólnota Europejska)/ Κατασκευαστής ή όκνηνο ηνπηθώλ αληηπηζνζώπσλ/ Üretici ya da Bölgedeki Yetkili Temsilci/ Proizvajalec ali pooblašteni zastopnik s sedežem v EU/ V'robca alebo zástupca so stálym bydliskom v EÚ / Изготовитель или его представитель, зарегистрированный в стране Содружества/ Tootja või organisatsioonis paiknev esindaja/ Ražotājs vai vietējais uzņēmuma pārstāvis / Gamintojas arba šalyje reziduojantis atstovas:
- (5) Date/ Datum/ Data/ Fecha/ datum/ Dato/ päiväys/ Kuupäev/ Datums/дата / Datum/ dátum/ tarih/ ημερομηνία
- (6) Authorised signatory/ Im Auftrag/ pour ordre/ Incaricato/ Por orden de/ por procuração/ op last van/ på vegne af/ på uppdrag/ Etter oppdrag/ psta./ Ülesandel / pavedus / v.i. / По поручению / megbízásából / длъжностно лице / z pověřeni / z poverenia / po nalogu / na polecenie / din sarcina / adina / θανά' εληνηή

- If you can read this text, your declaration is not complete. In this case please ask for a copy*
- (1) Type: **XX XX – Self-propelled industrial truck**
 - (2) Serial No: **XXXXXXXX**
 - (3) Year of constr.: **YYYY**
 - (4) Manufacturer or his authorized representative in Community:
Company Name/ Street / Postal code Town/ Country
 - (5) Date: **YYMM.DD**
 - (6) Authorized signatory: **Mr. Sample**